



The AX 300SE Series Specifications

AX 300SE

The SE Series products are reliable, cost-effective x-ray film processors that consistently produce high quality, beautifully-finished radiographs. The extraordinary value of the SE processors comes from the combination of over 30 years of technical improvements and ISO 9000 manufacturing excellence.

Processing time:	150 seconds (leading edge transport time)
Processing Capacity:	60 - 14 in x 17 in (35 cm x 43 cm) films per hour
Dimensions	
Processor:	height 18 in (45.7 cm) width 22 in (56 cm) length 32.5 in (82.5 cm)
Base:	height 30 in (76cm)
Water Consumption:	1/2 gal (1.9 liters) per minute - processing 1/4 gal (1 liter) per minute - standby
Tank Capacities:	developer 1.75 gal (6.6 liters) fixer 1.25 gal (4.7 liters) wash 1.25 gal (4.7 liters)
Developer Temperature:	± .5F Digitally displayed
Weight:	150 lbs. (68 kg) - without fluids
Power Requirements:	120 VAC, 15 Amps 240 VAC 7.5 Amps (optional)

AX 390SE

The AX 390SE is a 90-second version of the AX 300SE.

Processing time:	90 seconds (leading edge transport time)
Processing Capacity:	120 14x17 in (35 x 43 cm) films per hour
Water Consumption:	1/2 gal (1.9 liters) per minute - processing 1/4 gal (1 liter) per minute - standby
Developer Temperature:	± .5F Digitally displayed
Weight:	157 lbs. (71.2 kg) - without fluids
Power Requirements:	120VAC 15 Amps 240 VAC 7.5 Amps (optional)

See Installation and Service Manual for more complete information.
(Specifications subject to change without notice)



[CLICK FOR SITE SPECS](#)

1 Year Warranty

The Alphatek AX 300SE and AX 390SE Processors are warranted for a period of one year from the date of installation for all parts and against defects in material or workmanship. Should any such defect appear during the warranty period, notify your Alphatek dealer.

This warranty is for parts only and not for labor. This warranty does not cover damage caused by accident, misuse or neglect.

This warranty is in lieu of, and supersedes all other representations, expressed or implied, by the manufacturer or any representatives.

This warranty is provided for the original purchaser and is not transferable.

This warranty is void if any service or



The AX 300SE Series Specifications

AX 300SE Series Site Specifications & Preparation

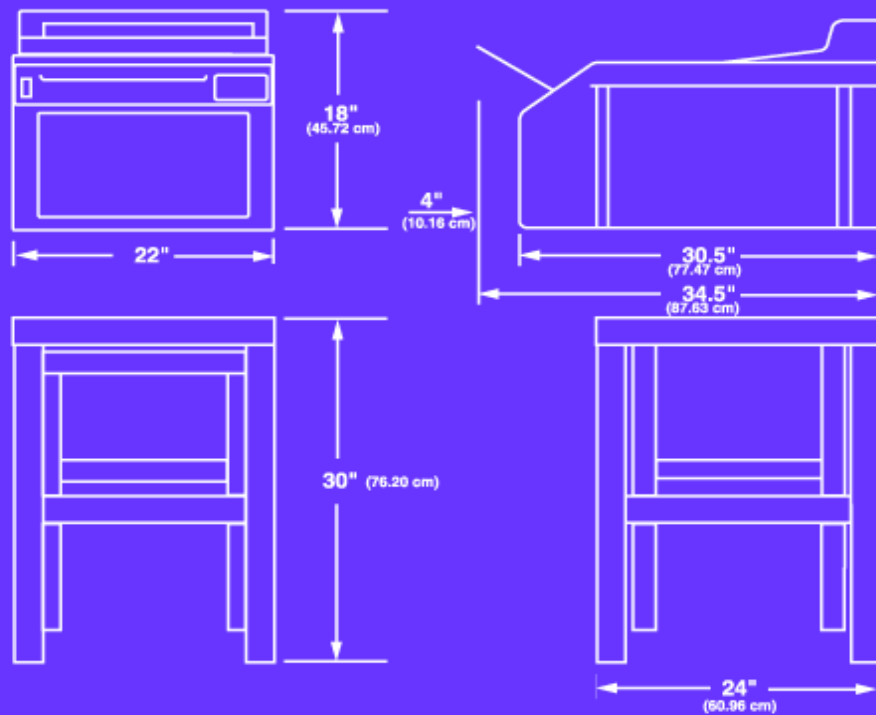

NOTE: All installations must comply with all national, state and local building codes and plumbing specifications must comply with E.P.A. and Metropolitan Sanitary District regulations.

2.1 ELECTRIC

- 120 Volts, 15 Amp., 50/60 Hz
- 240 Volts, 10 Amp., 50/60 Hz, optional
- 3 prong grounded outlet required
- Power cord length is approximately 90 inches (2.3 M)

2.2 DARKROOM ENVIRONMENT

- Room temperature should be maintained between 60°- 80°F (15°- 27°C)
- Relative humidity should be maintained between 40%-75%.
- Heat load from the processor is 5000 BTU's/hr.(maximum)
- Room must have an exhaust fan capable of 10 air changes per hour.



The AX 300SE Series Specifications

2.3 PLUMBING

- 2.3.1 Water temperature from the incoming cold water supply should be maintained between 40°- 95°F (4°- 35°C).
- 2.3.2 Water pressure should be between 40-80 PSI.
- 2.3.3 Water filtration may be required depending on local water conditions.
- 2.3.4 A sink with a hot and cold water source close to the processor or darkroom is suggested. The sink should be large enough to accommodate a transport rack for cleaning.
- 2.3.5 Processor is supplied with a 6 Ft. (1.8M) Water Inlet Hose. The hose has a 3/4 inch garden hose fitting at each end. Hose washers (supplied) must be installed to prevent leaks.
The cold water supply should be provided through a valve in the darkroom. Valve should be located within 4 feet (1.2 m) of the "Feed" side of the processor.
- 2.3.6 A floor drain capable of accepting 2 Gallons per minute (7.6 L/minute) is required. The drain must be vented and must not be higher than 12 inches (30 cm) from the floor.
- 2.3.7 Processor is supplied with 4 vinyl drain tubes, 6 Ft. (1.8 M) long. The tubes are 3/4 inch O.D (1.9 cm) and attach to the drain lines located inside the electrical section of the processor.
- 2.3.8 Drain lines should be installed with a gradual slope to the floor drain, ensuring there are no kinks or bends. This will provide for efficient drainage and avoid air locks.

2.4 PROCESSOR DIMENSIONS:

- Length :30.5 Inches (77 cm)
:33.5 Inches (85 cm) (including feed tray)
- Height :18 Inches (46 cm)
- Width :22 Inches (56 cm)
- Base Height :26 3/4 inches to 27 inches (68 cm to 69 cm)
- Weight :150 LBS. (68 kg)
- With Solutions :182 LBS. (83 kg)

2.5 ACCESS RECOMMENDATIONS

The processor should be installed in a location where proper servicing is achievable. Listed below are recommendations for proper clearance:

- Complete access to one side of the processor, preferably the "drive side".
Minimum clearance of 24 inches (61cm).
- Feed side: 30 inches (76cm).
- Top side: 15 inches (38cm).

This brochure was put together
by A Walsh Imaging
55 Cannonball Road
Pompton Lakes, NJ 07442

Tel 1-866-429-9729
Web www.awalshimaging.com

Dealer Information

A Walsh Imaging, Inc.
55 Cannonball Road
Pompton Lakes, NJ 07442

Phone 1-866-429-9729
Web www.awalshimaging.com